

## 800AJ BOOM LIFT

### 80FT DIESEL BOOM LIFT ARTICULATED

#### Performance

Platform Height	80 ft	24.38 m
Horizontal Outreach	51 ft 10 in.	15.8 m
Up and Over Height	32 ft 1 in.	9.78 m
Swing	360 Degrees Continuous	
Platform Capacity	500 lb	227 kg
Platform Rotator	180 Degrees Hydraulic	
Jib Range of Articulation	130 Degrees (+7Q, -6Q)	
Weight	35,520 lb	16,110 kg
Drive Speed Lowered	3.45 mph	5.55 km/h
Drive Speed Elevated	0.27 mph	0.43 km/h
Gradeability 4WD	45%	
Axle Oscillation	8 in.	204 cm
Ground Bearing Pressure	76 psi	5.3 kg/cm <sup>2</sup>
Turning Radius (ZWS)		
Inside	12 ft 6 in.	3.8 m
Outside	19 ft 8 in.	6.02 m

#### Standard Specifications

##### Power Source

Diesel Engine		
Kubota Tier 4 Final	25 hp	18.6 kW
Motor/Generator Power	30 hp	22.3 kW
Fuel Tank Capacity	25 gal.	94.64 L
Batteries	12V 205 AH Maintenance free AGM	
System Voltage	84V	
Battery Quantity	14	

##### Hydraulic System

• Capacity	40 gal.	151.42 L
• Auxiliary Power	12V DC	

##### Tires

• Standard	15-625 Foam Filled
• Optional	18-625 Foam-Filled 18-625 Non Marking Foam Filled

#### Standard Features

- Oscillating Axle
- 180 Degree Hydraulic Platform Rotator
- 110V-AC Receptacle in the Platform
- 5 Degree Tilt Alarm/Indicator Light
- Automatic Engine Idle, Start/Stop
- Automatic Battery Charger in Hybrid Mode
- Electric Only Capability
- Swing-Out Engine Tray
- 12V-DC Auxiliary Power
- Hourmeter
- Horn
- Control ADE\* System
- Proportional Controls
- Gull-Wing Engine Hood
- Platform Console Machine Status Light Panel\*
- Lifting/Tie Down Lugs
- All Motion Alarm
- Load Sensing System
- SkyGuard SkyLine™
- Glow Plugs (Diesel Engines)

\* Provides indicator lights at platform control console for system distress, 5 degree tilt light, and foot switch status.



#### Accessories & Options

- Fall Arrest Platform, Rear Entry<sup>1</sup>: 36 x 96 in. (0.91 x 2.44 m)
- Self-Closing Gate
- Soft-Touch System
- Operator Tool Tray
- 1/2 in. Airline to Platform
- Exhaust Purifier Muffler (Diesel)
- Cold Weather Start Kit<sup>2</sup>
- Hostile Environment Kit<sup>3</sup>
- Light Package<sup>4</sup>
- Flashing Amber Beacon
- SkySense™
- Accessory Packages:
  - SkyPower®
  - SkyWelder®

1. Foam-filled tires required.  
2. Includes glow plugs (Diesel), battery heater, oil tank heater.  
3. Includes console cover, boom wipers and cylinder bellows.  
4. Includes head and tail lights, platform worklights and beacon.

Note: Some options may increase lead time, and some option combinations may not be available.

Additional accessories and options available via JLG Aftermarket.

## 800AJ BOOM LIFT

### 80FT DIESEL BOOM LIFT ARTICULATED

#### Dimensions

All dimensions are approximate.

##### H800AJ

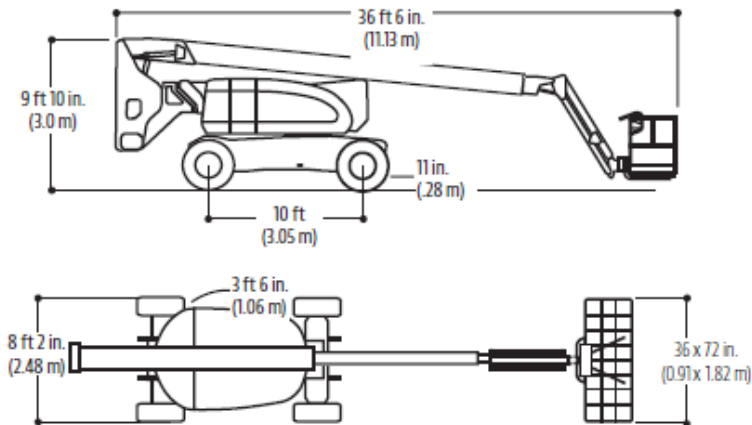

#### Reach Diagram

##### H800AJ

