

[HIRE](#)
[SALES](#)
[SERVICE](#)
[LEASE](#)
[TRANSPORT](#)

## 533-105 TELEHANDLER

### 3.3T DIESEL 10.5M TELEHANDLER



SPECIFICATION LOADALL CONSTRUCTION RANGE

#### STATIC DIMENSIONS

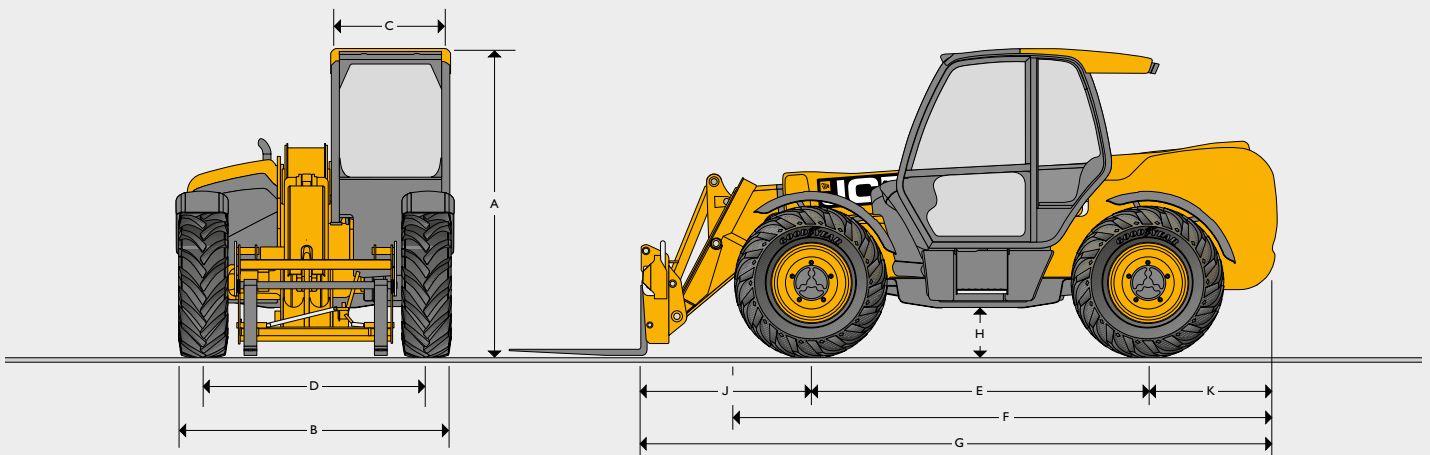

#### STATIC DIMENSIONS

Machine model		531-70	541-70	535-95	533-105	535-125 HiViz	540-140 HiViz	540-170	540-180 HiViz	540-200
A Overall height	m	2.49	2.49	2.49	2.49	2.59	2.59	2.69	2.59	2.72
B Overall width (over tyres)*	m	2.23	2.23	2.36	2.36	2.35	2.35	2.44	2.35	2.44
C Inside width of cab	m	0.94	0.94	0.94	0.94	0.94	0.94	0.94	0.94	0.94
D Front track	m	1.81	1.81	1.87	1.87	1.90	1.90	1.90	1.90	1.97
E Wheelbase	m	2.75	2.75	2.75	2.75	2.75	2.75	2.75	2.75	2.75
F Overall length to front tyres	m	4.38	4.38	4.38	4.38	4.74	4.74	5.08	4.75	5.09
G Overall length to front carriage	m	4.99	4.99	4.99	5.38	5.80	6.23	6.36	6.27	6.81
H Ground clearance	m	0.40	0.40	0.40	0.40	0.40	0.40	0.40	0.40	0.41
J Front wheel centre to carriage	m	1.25	1.25	1.20	1.62	1.68	2.11	1.94	2.15	2.39
K Rear wheel centre to rear face	m	0.99	0.99	1.04	1.01	1.37	1.37	1.67	1.37	1.67
Overall width with stabilisers fully deployed	m	NA	NA	NA	2.63	2.57	2.57	3.55	3.39	3.82
Outside turn radius (over tyres)	m	3.7	3.7	3.7	3.7	3.75	3.75	4.1	3.75	4.1
Carriage rollback angle	degrees	42.6	42.6	41.0	41.2	37.0	37.0	39	36.5	39
Carriage dump angle	degrees	37.5	37.5	24.0	24.0	12.5	12.5	8.8	12.5	8.8
Weight	kg	7060	7850	8215	8850	10066	10880	12060	11380	12985
Tyres		400/80 - 24	400/80 - 24	400/80 - 24	400/80 - 24	400/80 - 24	400/80 - 24	440/80 - 24	400/80 - 24	440/80 - 24

\* Type dependent

[WA](#)
[NT](#)
[QLD](#)
[NSW](#)
[VIC](#)
[SA](#)

HIRE

SALES

SERVICE

LEASE

TRANSPORT

## 533-105 TELEHANDLER 3.3T DIESEL 10.5M TELEHANDLER



### SPECIFICATION LOADALL CONSTRUCTION RANGE

#### LIFT PERFORMANCE

	531-70	541-70	535-95	535-95 sway*
Maximum lift capacity	kg 3100	kg 4100	kg 3500	kg 3500
Lift capacity to full height	kg 2400	kg 2250	kg 1500	kg 1600
Lift capacity at full reach	kg 1250	kg 1500	kg 450	kg 450
Lift height	m 7.0	m 7.0	m 9.50	m 9.50
Reach at maximum lift height	m 0.54	m 0.54	m 2.49	m 2.49
Maximum forward reach	m 3.7	m 3.7	m 6.52	m 6.52
Reach with 1 tonne load	m 3.7	m 3.7	m 4.73	m 4.73
Placing height	m 6.3	m 6.3	m 8.78	m 8.78

Complies with stability test EN 1459 Annex B, chassis levelling (sway) with stabilisers retracted (sway angle  $\pm 9^\circ$ ).

#### LIFT PERFORMANCE

	533-105 stabilisers retracted	533-105 stabilisers extended	535-125 HiViz stabilisers retracted sway*	535-125 HiViz stabilisers extended sway*
Maximum lift capacity	kg 3300	kg 3300	kg 3500	kg 3500
Lift capacity to full height	kg 1000	kg 2500	kg 1500	kg 3500
Lift capacity at full reach	kg 325	kg 1000	kg 125	kg 1200
Lift height	m 9.85	m 10.22	m 11.7	m 12.27
Reach at maximum lift height	m 2.69	m 1.99	m 2.01	m 0.54
Maximum forward reach	m 6.94	m 6.83	m 8.06	m 8.06
Reach with 1 tonne load	m 4.65	m 6.83	m 5.06	m 8.06
Placing height	m 9.44	m 9.82	m 11	m 11.75

Complies with stability test EN 1459 Annex B, chassis levelling (sway) with stabilisers retracted (sway angle  $\pm 9^\circ$ ).

\* Sway levelling is optional, performance may vary when not fitted.

▲ Standard machine software interlock - 45° boom angle limit, configurable upon service request.

WA

NT

QLD

NSW

VIC

SA

[HIRE](#)
[SALES](#)
[SERVICE](#)
[LEASE](#)
[TRANSPORT](#)

## 533-105 TELEHANDLER

### 3.3T DIESEL 10.5M TELEHANDLER



#### SPECIFICATION LOADALL CONSTRUCTION RANGE

ENGINE	531-70	541-70	535-95	533-105	535-125 HiViz	540-140 HiViz	540-170	540-180 HiViz	540-200
JCB 430 DieselMAX Stage V, 3 litre, 4 cylinder, turbo charged	Standard	N/A	Standard	Standard	Standard	Standard	Standard	Standard	Standard
Engine 55kW (74hp) @ 2200rpm, 440Nm torque at 1300rpm	Standard	N/A	Standard	Standard	Standard	Standard	Standard	Standard	Standard
JCB 448 DieselMAX Stage V, 4.8 litre, 4 cylinder, turbo charged	Option	Standard	Option	Option	Option	Option	Option	Option	Option
Engine 81kW (109hp) @ 2200rpm, 516Nm torque at 1300rpm	Option	Standard	Option	Option	Option	Option	Option	Option	Option

HYDRAULIC CYCLE TIMES	531-70	541-70	535-95	533-105	535-125 HiViz	540-140 HiViz	540-170	540-180 HiViz	540-200
Boom raise	7.2	8.8	9.1	8.8	10.4	13.5	22.7	13.8	17.3
Boom lower	5.4	6.5	7.7	8.5	8.1	11	23.4	10.2	15.9
Extend	6.8	6.8	10.5	13.2	15.7	15.6	18.3	22.4	28.1
Retract	5	5	11.2	13.6	12.8	14.4	16.7	17.9	22.7
Bucket dump	3.5	3.5	2.4	2.4	2.9	2.9	4.2	2.9	6.1
Bucket crowd	2.9	2.9	3.5	3.4	2.6	2.6	4.6	2.6	5.9

HYDRAULICS	Hydraulic System Pressure (bar)		Max. Pump flow (litres)	
531-70	240		82	
541-70	260		82	
535-95	240		82	
533-105	240		82	
535-125	260		110	
540-140	260		110	
540-170	260		170	
540-180	260		110	
540-200	260		110	

NOISE AND VIBRATION	55kW	81kW	93kW	Uncertainty	Measurement conditions.	
Noise at the operator station	LpA	77	80	81	+/- 1 dB	Determined in accordance with the test method defined in EN12053.
Noise emission from the machine LWA		104	106	107	+/- 1 dB	Guaranteed equivalent sound power (external noise) determined in accordance with the dynamic test conditions defined in 2000/14/EC.
Hand-arm vibration	m/s <sup>2</sup>	<2.5	<2.5	<2.5	N/A	ISO 5349-2:2001 dynamic test conditions.

<b>TRANSMISSION</b>	Torque converter, 4 speed powershift gearbox. Travel speed 531-70, 541-70, 535-95, 533-105: 29kph, 33kph (when 2/4WD select is specified). Travel speed 535-125, 540-140, 540-180: 29kph. Optional 33kph transmission. Travel speed 540-170, 540-200: 29kph.
<b>BRAKING</b>	531-70, 541-70, 535-95, 533-105: Servo-assisted: Front axle, oil-immersed multi-disc, automatic 4-wheel drive braking Parking brake: Hand operated disc brake on gearbox output. 535-125, 540-140, 540-170, 540-180, 540-200: Servo-assisted: Front and Rear axle, oil immersed multi-disc, automatic 4-wheel drive braking Parking Brake: Hand operated disc brake on gearbox output.
<b>CAB</b>	Conforms to ROPS ISO 3471 and FOPS ISO 3449
<b>OPTIONS</b>	Front and rear working lights, rotating flashing beacon, fire extinguisher, traction and industrial tyres, electrical 2/4WD select, limited slip differential in front axle, windscreen and roof guard, air suspension seat, deluxe cab trim, roof and front screen blind, radio kit, air conditioning, reversing fan, deluxe trim, armrest (SLC only), roof moulding. Single lever mechanical joystick, with push button extend and retract. Single lever servo joystick option on 535-125, 540-140, 540-170, 540-180 & 540-200. Options of rear or rear & offside reversing cameras. Centralised greasing available on the 540-180 HiViz.

[WA](#)
[NT](#)
[QLD](#)
[NSW](#)
[VIC](#)
[SA](#)