

HIRE

SALES

SERVICE

LEASE

TRANSPORT

560-80 IND TELEHANDLER

6.0T DIESEL 7.9M TELEHANDLER



STATIC DIMENSIONS

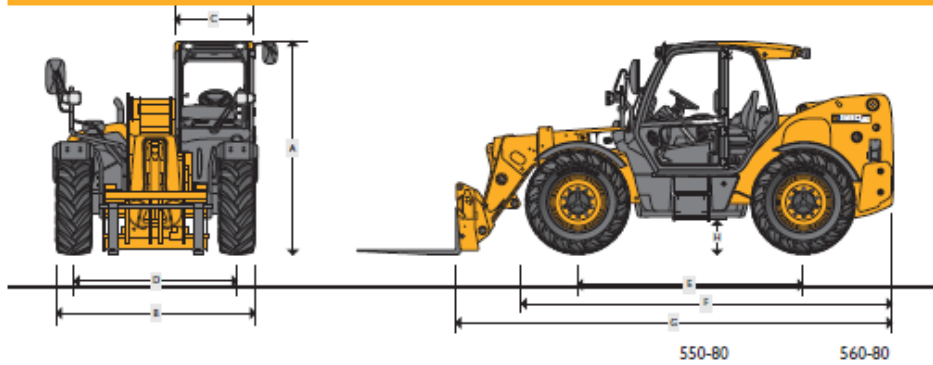

		550-80	560-80
A	Overall height	m	2.59
B	Overall width (over tyres)*	m	2.42
C	Inside width of cab	m	0.94
D	Front track	m	1.98
E	Wheelbase	m	2.75
F	Overall Length to front of tyres	m	4.42
G	Overall length to front of carriage	m	5.27
H	Ground clearance	m	0.4
	Outside turn radius (over tyres)	m	4.1
	Carriage rollback angle	degrees	47
	Carriage dump angle	degrees	33
	Weight**	kg	10530
	Tyres		440/80 R24

* Dependant upon tyre specified.

** Dependant upon tyre specified and machine specification.

LIFT PERFORMANCE

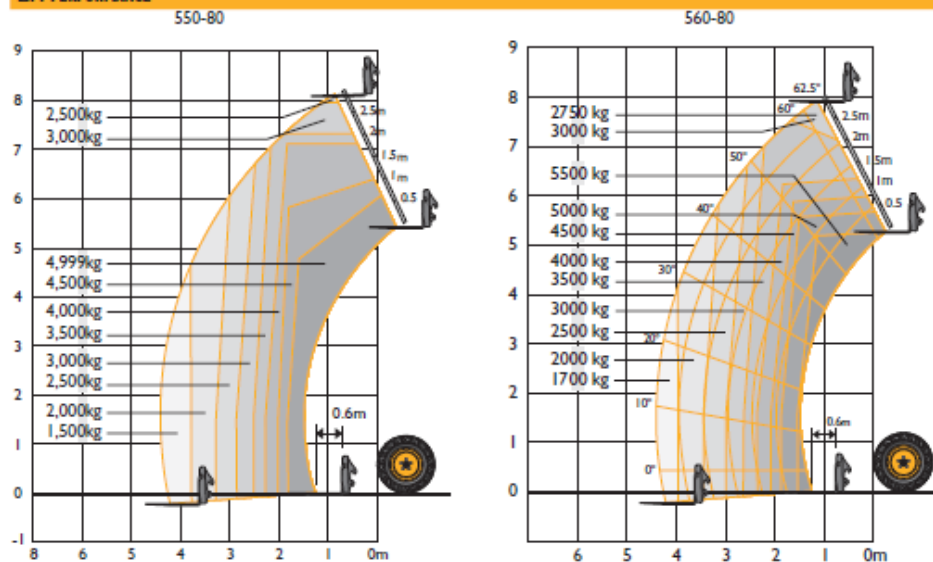

		550-80	560-80
Maximum lift capacity	kg	4999	5500
Lift capacity to full height	kg	2500	2750
Lift capacity at full reach	kg	1500	1700
Lift height	m	8.1	7.9
Reach at maximum lift height	m	0.97	0.92
Maximum forward reach	m	4.47	4.41
Reach with 1 tonne load	m	4.47	4.41
Placing height	m	7.45	6.64

Complies with stability test EN 1459 Annex B.

WA

NT

QLD

NSW

VIC

SA

[HIRE](#)
[SALES](#)
[SERVICE](#)
[LEASE](#)
[TRANSPORT](#)

560-80 IND TELEHANDLER

6.0T DIESEL 7.9M TELEHANDLER



ENGINE		
Emissions level		T4i
Manufacturer		JCB
Displacement	litres	4.4/4.8
No of Cylinders		4
Bore size	mm	103/106
Stroke	mm	132/135
Aspiration		TCA
Power rating		
Power @ 2200rpm	kW (hp)	93 (125)/108 (145)
Torque rating		
Torque @ 1500rpm	Nm (lb/ft)	550 (406)/560 (413)
Engine oil service intervals		500 hours
After treatment		NIL

TRANSMISSION	
JCB Powershift Transmission incorporating torque converter and a bevel box in one resiliently mounted unit.	
Manual gear shift incorporated onto the single lever joystick. Travel speed 40kph (dependant upon tyre selection) 2/4 WD disconnect.	
Front and rear drive axles: Epicyclic hub reduction drive/steer axles with torque proportioning differentials.	
Agri Plus: 4 Speed Manual	
Agri Super: 6 Speed Manual/Automatic with torque lock in 5th and 6th gear.	

HYDRAULICS			
Operating system pressure	bar	260	
Main hydraulics	l/min	140	
Pump	l/min	Variable	
Loader controls		Cab mounted single lever joystick (Seat mounted optional) – Electric servo control of all lift end functions.	
Hydraulic cycle times		seconds	
		550-80	560-80
Boom raise		7.4	
Boom lower		5.9	8.3
Extend		8.3	
Retract		5.9	
Bucket dump		2.8	
Bucket crowd		3	

ELECTRICAL SYSTEM		
System voltage	Volt	12
Alternator output	Amp hour	150
Battery capacity	Amp hour	220
Full road lighting. Reversing light. Directional indicators. Hazard warning. Reverse alarm.		

SERVICE CAPACITIES		
Fuel tank	litres	146
Hydraulic tank	litres	112
Engine oil sump	litres	14
Engine coolant system	litres	23

[WA](#)
[NT](#)
[QLD](#)
[NSW](#)
[VIC](#)
[SA](#)

560-80 IND TELEHANDLER

6.0T DIESEL 7.9M TELEHANDLER



BRAKES

Service brakes: Hydraulically activated power brakes, self-adjusting, oil-immersed in-board multi-disc type on front and rear axles.

Parking brake: Hand operated oil immersed disc type.

BOOM AND CARRIAGE

Boom is manufactured from high tensile steel. Low maintenance, hard wearing pads. JCB Q-fit self-levelling carriage with lever operated pin locking accepts pallet forks and a wide range of attachments. One boom end auxiliary hydraulic service fitted as standard.

SAFETY CHECK VALVES

Fitted to carriage tilt, telescopic and boom lift rams.

NOISE AND VIBRATION

		Measurement conditions
Noise at the operator station (LpA)	78dB	In accordance with ISO6369 in a test defined in 2000/14/EC
Noise emission from the machine (LWA)	107dB	External noise determined in accordance with test defined in 2000/14/EC
Whole body vibrate emission	0.42m ²	In accordance with ISO 2631-1:1997

STEERING

Hydrostatic power steering with power track rods on both axles. Three steer mode options: front wheel steer; all wheel steer; crab steer: operated from in the cab by a selection switch, with automatic alignment.

CAB

Quiet, safe and comfortable cab conforms to ROPS ISO 3471 and FOPS ISO 3449. Tinted glass all round with laminated front and roof screen. Roof bars, front, rear and roof screen wash/wipe and heater/screen demister. Opening rear window. Audio-visual warning system for coolant temperature, water in fuel, engine oil pressure, air cleaner, battery charge, transmission oil temperature and pressure. Brake charge, hourmeter and road speed indicator. Engine temperature, fuel gauge and clock. Adjustable steer column with forward reverse shuttle. Floor mounted throttle pedal. Adjustable deluxe suspension seat with adjacent park brake. Automatic eye level audio-visual load moment indicator warning system receiving a signal from a load sensor on the rear axle.

This system continuously monitors the machine's forward stability and leaves the operator in control at all times.

Hydraulic controls: Cab mounted single lever servo joystick, incorporating forward/neutral/reverse, with progressive extend/retract and auxiliary incorporating constant flow facility. Seat mounted single lever servo joystick incorporating forward/neutral/reverse, with progressive extend/retract and auxiliary incorporating constant flow facility.

OPTIONS AND ACCESSORIES

Options: Front, rear and boom working lights, rotating flashing beacon, fire extinguisher, 26" agricultural and industrial tread pattern tyre option, radial industrial tyres, limited slip differential in front axle, windscreen and roof guard, air suspension seat, roof and front screen blind, radio kit, air conditioning, 2 speed and intermittent front wash/wipe, Smoothride system, towing facility with trailer lighting package, variable speed fan and reversing fan as standard, optional auto reverse fan, 2nd boom auxiliary, carriage options available – contact your local dealer.

Attachments: Contact your local dealer for details of the comprehensive range.

Adaptive load control for AUS conforms to AS 1418.19