

[HIRE](#)
[SALES](#)
[SERVICE](#)
[LEASE](#)
[TRANSPORT](#)

Z-60/37FE BOOM LIFT

60FT BI-ENERGY ARTICULATING BOOM LIFT



Model	Z-60/37FE	
Measurements	Metric	US
Working height maximum*	20.16 m	65 ft 7 in
Platform height maximum	18.16 m	59 ft 7 in
Horizontal reach maximum	11.15 m	36 ft 7 in
Up and over clearance maximum	7.39 m	24 ft 3 in
▲ Platform length	0.91 m	3 ft
▲ Platform width	2.44 m	8 ft
▲ Height - stowed	2.54 m	8 ft 4 in
Height - transport (jib tucked under)	2.62 m	8 ft 7 in
▲ Length - stowed	8.15 m	26 ft 9 in
Length - transport (jib tucked under)	6.30 m	20 ft 8 in
▲ Width	2.49 m	8 ft 2 in
▲ Wheelbase	2.49 m	8 ft 2 in
▲ Ground clearance - center	0.33 m	1 ft 1 in

Productivity

Lift capacity	227 kg	500 lbs
Platform rotation	160°	160°
Vertical jib rotation	135°	135°
Turntable rotation	355° non-continuous	
Turntable tailswing - riser up	0.58 m	1 ft 11 in
Turntable tailswing - riser down	0.81 m	2 ft 8 in
Drive speed - stowed	6.4 km/h	4.0 mph
Drive speed - raised**	1.0 km/h	0.7 mph
Gradeability - stowed***	45%	45%
Turning radius - inside	2.51 m	8 ft 3 in
Turning radius - outside	5.69 m	18 ft 8 in
Controls	24V DC proportional	
Tyres	355/55D 625	

Power

Drive system	34 V 3-Phase AC	
Power source	48 V DC (eight 6 V batteries) 390 Ah capacity 24.8 hp (18.5 kW) Kubota D1105 T4f driven AC generator	
Auxiliary power unit	12 V DC	12 V DC
Hydraulic tank capacity	68.4 L	18 gal
Fuel tank capacity	64.4 L	17 gal

Sound & Vibration Levels

Sound pressure level (ground workstation)	77 dBA
Sound pressure level (platform workstation)	72 dBA
Vibration	0.55 m/s ² (1.81 ft/s ²)

Weight****

Z-60/37FE	7,686 kg	16,944 lbs
-----------	----------	------------

Standards Compliance

AS 1418.10

Range Of Motion Z-60/37FE

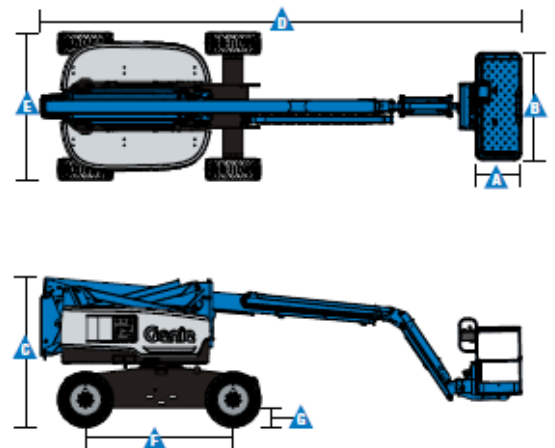
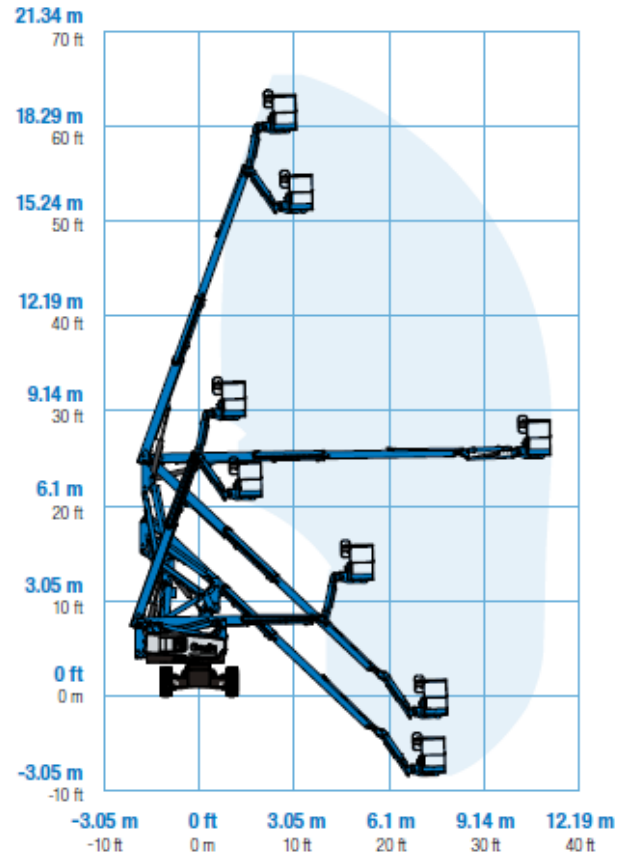
[WA](#)
[NT](#)
[QLD](#)
[NSW](#)
[VIC](#)
[SA](#)

Z-60/37FE BOOM LIFT

60FT BI-ENERGY ARTICULATING BOOM LIFT



Features

Standard Features

Measurements

- 20.16 m (65 ft 7 in) working height
- 11.15 m (36 ft 7 in) horizontal reach
- 7.39 m (24 ft 3 in) up and over clearance
- Up to 227 kg (500 lbs) lift capacity

Productivity

- 1.52 m (5 ft) jib boom with 135° working range
- Digital hour meter with battery charge indicator and diagnostic readout
- 4 Wheel AC electric drive system
- Variable speed high efficiency hydraulic power unit
- Self-levelling platform
- Hydraulic platform rotation
- Proportional joystick controls
- Telematics Ready Connector
- Thumb rocker steering
- Drive enable
- AC power cord to platform
- Horn
- Hour meter
- Tilt alarm
- Descent & travel alarms
- Flashing beacon
- Tilt cut-out
- 355° non-continuous turntable rotation
- Locking turntable covers
- Positive traction drive
- Certified load sensor
- Lockable platform control box cover

Power

- 48 V DC battery pack (390 Ah)
- 12 V DC auxiliary power
- 25 A temperature compensated smart charge system
- Battery charge indicator
- Low battery voltage interrupt

Platform

- Steel 2.44 m (8 ft) tri entry with side swing gate

Engine

- 18.5 kW (24.8 hp) Kubota T4 diesel

Drive

- 4WD Electric AC

Axle

- Active oscillation

Tyres

- Rough terrain non-marking foam filled

Options & Accessories

Productivity Options

- Half mesh platform inserts
- Air line to platform
- 240 V power to platform
- Work lights package
- Biodegradable hydraulic oil
- Operator Protective Structure
- Operator Protective Alarm

