

GS-3268 RT SCISSOR LIFT

32FT DIESEL ROUGH TERRAIN SCISSOR LIFT

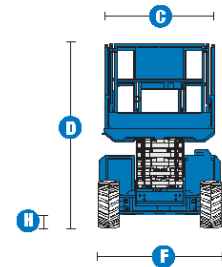

MODELS	GS™-2668 RT		GS™-3268 RT	
MEASUREMENTS	Metric	US	Metric	US
Working height maximum	9.75 m	32 ft	11.58 m	38 ft
A Platform height maximum	7.9 m	26 ft	9.75 m	32 ft
B Platform length - outside	2.51 m	99 in	2.51 m	99 in
- extended	3.96 m	156 in	3.96 m	156 in
Slide-out platform extension deck	1.52 m	60 in	1.52 m	60 in
C Platform width - outside	1.55 m	61 in	1.55 m	61 in
Toeboard height	15 cm	6 in	15 cm	6 in
Platform height - stowed	1.19 m	3 ft 10.75 in	1.31 m	4 ft 3.75 in
D Height - stowed (guardrails)	2.32 m	7 ft 7.5 in	2.45 m	8 ft 5 in
(guardrails lowered)	1.7 m	67 in	1.83 m	72 in
E Length - stowed	2.67 m	8 ft 9 in	2.67 m	8 ft 9 in
platform extended	4.10 m	13 ft 5.5 in	4.10 m	13 ft 5.5 in
with outriggers	3.28 m	10 ft 9 in	3.28 m	10 ft 9 in
F Width	1.73 m	68 in	1.73 m	68 in
G Wheelbase	1.85 m	73 in	1.85 m	73 in
H Ground clearance - centre	19 cm	7.5 in	19 cm	7.5 in

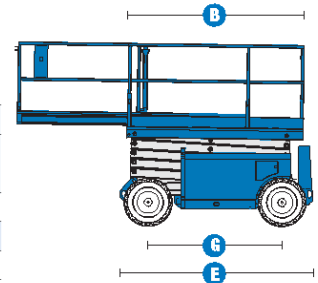

PRODUCTIVITY				
Lift capacity	567 kg	1,250 lbs	454 kg	1,000 lbs
Drive speed - stowed	5.3 km/h	3.3 mph	5.3 km/h	3.3 mph
Drive speed - raised	0.8 km/h	0.5 mph	0.8 km/h	0.5 mph
Gradeability	30%		25%	
Maximum outrigger leveling:				
front to back	6.6%	6.6%	6.6%	6.6%
side to side	10.6%	10.6%	10.6%	10.6%
Turning radius - inside	1.52 m	60 in	1.52 m	60 in
Turning radius - outside	3.68 m	145 in	3.68 m	145 in
Raise/lower speed	30/35 sec	30/35 sec	50/37 sec	50/37 sec
Controls	proportional	proportional	proportional	proportional
Drive	dual rear wheel		dual rear wheel	
Tyres contact pressure	593 kPa	86 psi	565 kPa	82 psi
Tyres - non-marking	23 x 55 cm	9 x 21.5 in	23 x 55 cm	9 x 21.5 in

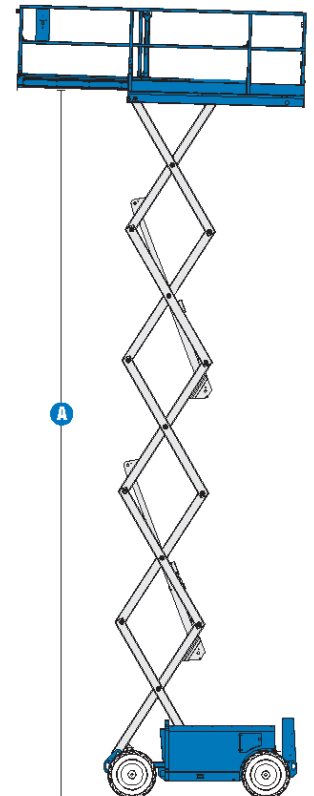

POWER				
Power source	48V (8 6V 350AH batteries)		48V (8 6V 350AH batteries)	
Auxiliary power unit	12 V DC	12 V DC	12 V DC	12 V DC
Fuel tank capacity	56.8 L	15 gal	56.8 L	15 gal
Hydraulic system capacity	62.5 L	16.5 gal	62.5 L	16.5 gal

WEIGHT				
	2,833 kg	6,247 lbs	3,621 kg	7,985 lbs

STANDARDS COMPLIANCE	
	ANSI/SIA A92.6 CSA CAN3-B354.2-M82 CE compliance option AS 1418.10