

## DCG280-12 FORKLIFT

### 28.0T DIESEL HEAVY DUTY FORKLIFT



## Dimensions.

### Model designation

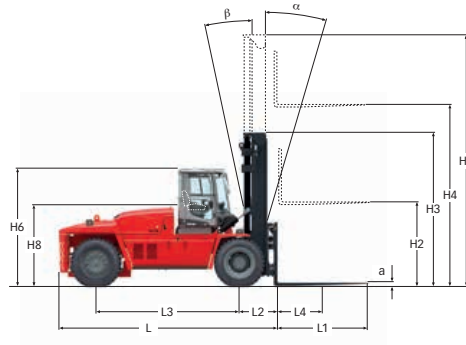
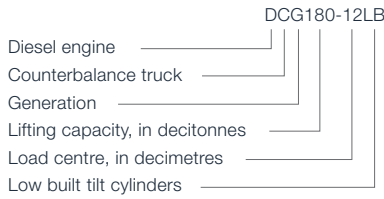

### Lifting capacity in tonnes

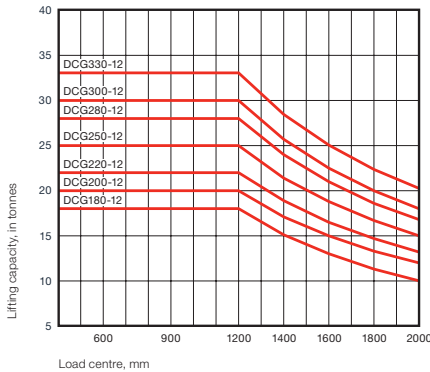

Load centre, mm

DCG180-250: Full lifting capacity up to 7000 mm lift height with duplex/duplex freelif mast, integrated sideshift/fork positioning carriage and forklift system.

DCG280-330: Full lifting capacity up to 7000 mm lift height with duplex/duplex freelif mast, integrated sideshift/fork positioning carriage and forklift system.

MAIN DATA	Model designation		
	Power source		
	Rated capacity / rated load	kg	
	Load center distance	mm	L4
	Load distance, center of drive axle to fork	mm	L2
WEIGHTS	Wheelbase	mm	L3
	Service weight	kg	
	Axle loading, unloaded front	kg	
	Axle loading, loaded front	kg	
	Axle loading, unloaded rear	kg	
WHEELS	Axle loading, loaded rear	kg	
	Type, front / rear		
	Tyre size, front	inch	
	Tyre size, rear	inch	
	Number of wheels, front / rear (x = driven wheels)		
DIMENSIONS	Track width, front / rear	mm	S
	Tyre pressure	MPa	
	Mast tilt, $\alpha$ = forward / $\beta$ = backward	°	$\alpha$ / $\beta$
	Height of mast lowered	mm	H3
	Lift height	mm	H4
	Height of mast extended	mm	H5
	Truck height - EGO / OHG cabin roof	mm	H6
	Seat height	mm	H8
	Height when tilting EGO cab / OHG	mm	T1
	Width when tilting EGO cab / OHG	mm	T2
	Truck length (to face of forks)	mm	L
	Truck width	mm	B
	Fork dimensions, width	mm	b
	Fork dimensions, thickness	mm	a
	Fork dimensions, length of fork arm	mm	l
Fork carriage width	mm	b3	
Width over fork arms, minimum / maximum	mm	V	
Sideshift $\pm$ @ width over forks	mm	V1 / V	
OTHERS	Ground clearance, laden, below mast	mm	
	Ground clearance, machine	mm	
	Min. aisle width for 90° stacking with forks	mm	A1
	Turning radius	mm	R1
	Internal turning radius	mm	R2
	Operating pressure for hydraulics	MPa	
	Hydraulic oil tank, capacity	l	
Fuel tank, capacity	l		
AdBlue tank, capacity	l		

HIRE

SALES

SERVICE

LEASE

TRANSPORT

## DCG280-12 FORKLIFT

### 28.0T DIESEL HEAVY DUTY FORKLIFT

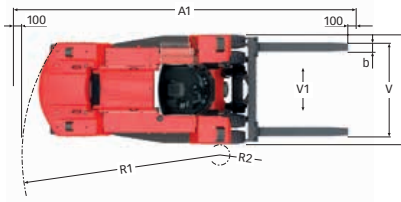
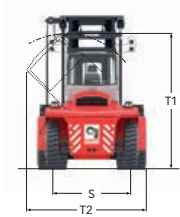

DCG180-12	DCG200-12	DCG220-12	DCG250-12	DCG280-12	DCG300-12	DCG330-12
DCG180-12	DCG200-12	DCG220-12	DCG250-12	DCG280-12	DCG300-12	DCG330-12
Diesel	Diesel	Diesel	Diesel	Diesel	Diesel	Diesel
18000	20000	22000	25000	28000	30000	33000
1200	1200	1200	1200	1200	1200	1200
1070	1070	1070	1070	1125	1125	1125
4000	4000	4000	4250	4750	4750	4750
28500	29800	31200	32900	38300	39500	41500
15000	15000	15000	15500	20500	20500	20500
43200	46300	49500	53800	61700	64900	68800
13500	14800	16200	17400	17800	19000	21000
3300	3500	3700	4100	4100	4300	4800
Pneumatic / Pneumatic						
14.00x24	14.00x24	14.00x24	14.00x24	16.00x25	16.00x25	16.00x25
14.00x24	14.00x24	14.00x24	14.00x24	16.00x25	16.00x25	16.00x25
4" - 2	4" - 2	4" - 2	4" - 2	4" - 2	4" - 2	4" - 2
2200 / 2140	2200 / 2140	2200 / 2140	2200 / 2140	2540 / 2440	2540 / 2440	2540 / 2440
1,0	1,0	1,0	1,0	1,0	1,0	1,0
5 / 10	5 / 10	5 / 10	5 / 10	5 / 10	5 / 10	5 / 10
4320	4320	4320	4320	4520	4520	4520
5000	5000	5000	5000	5000	5000	5000
6820	6820	6820	6820	7020	7020	7020
3270	3270	3300	3270	3415	3415	3415
2150	2150	2150	2150	2300	2300	2300
3800	3800	3800	3800	3800	3800	3800
3700	3700	3700	3700	3800	3800	3800
6090	6090	6090	6340	6925	6925	6925
3050	3050	3050	3050	3430	3430	3430
250	250	250	250	300	300	300
110	110	110	110	110	110	110
2400	2400	2400	2400	2400	2400	2400
2700 / 800	2700 / 800	2700 / 800	2700 / 800	3150 / 850	3150 / 850	3150 / 850
557 / 1585	557 / 1585	557 / 1585	557 / 1585	575 / 2000	575 / 2000	575 / 2000
-	-	-	-	-	-	-
300	300	300	300	300	300	300
9270	9270	9270	9550	10325	10325	10325
5600	5600	5600	5875	6600	6600	6600
425	425	425	550	950	950	950
16.5	18	20	22	19.5	20.5	22
330	330	330	330	330	330	330
300	300	300	375	450	450	450
35	35	35	35	35	35	35

WA

NT

QLD

NSW

VIC

SA